

Series 8 Profibus Gateway Module Specification



S803-160-110

Release 110

January 2014, Version 1

<https://maxautoland.com/>
manski@cambiala.cn +86 18030205725

Revision History

Revision	Date	Description
1.0	January 2014	Release Publication

<https://maxautoland.com/>
manski@cambia.cn +86 18030205725

Table of Contents

1.	Product Introduction	1
1.1.	Architecture Overview	1
1.2.	Series 8 Profibus Gateway Module Overview	2
2.	Specifications	3
2.1.	Series 8 Profibus Gateway Module Hardware	3
2.2.	Series 8 PGM & Control Processor Integration.....	7

<https://maxautoland.com/>
manski@cambia.cn +86 18030205725

1. Product Introduction

Experion™ LX is a member of Honeywell's Experion family, Experion LX is specifically designed to meet the customer needs in mid-tier markets (Chemicals, Industrial Power, F&B, Bio-fuels, ...), through integrating state-of-the-art technology from the award-winning Experion Process Knowledge System (PKS) with innovative design of Series 8 I/O modules and cabinets, validated wider range of COTS options, easy engineering and maintenance capabilities, and integrator-friendly programs and tools. Experion LX is the perfect platform for process, asset and business management with small to medium complexity, and enables customers to increase their profitability and productivity and accessibility to local support without sacrificing quality and reliability in an increasingly competitive environment.

1.1. Architecture Overview

The Experion LX platform comprises many different integrated hardware and software solutions depending upon the needs of the application. This pictured architecture is a representation of many of the possible nodes that can be used in the Experion LX architecture. Note that the architecture is highly scalable and not all nodes are necessary or required.

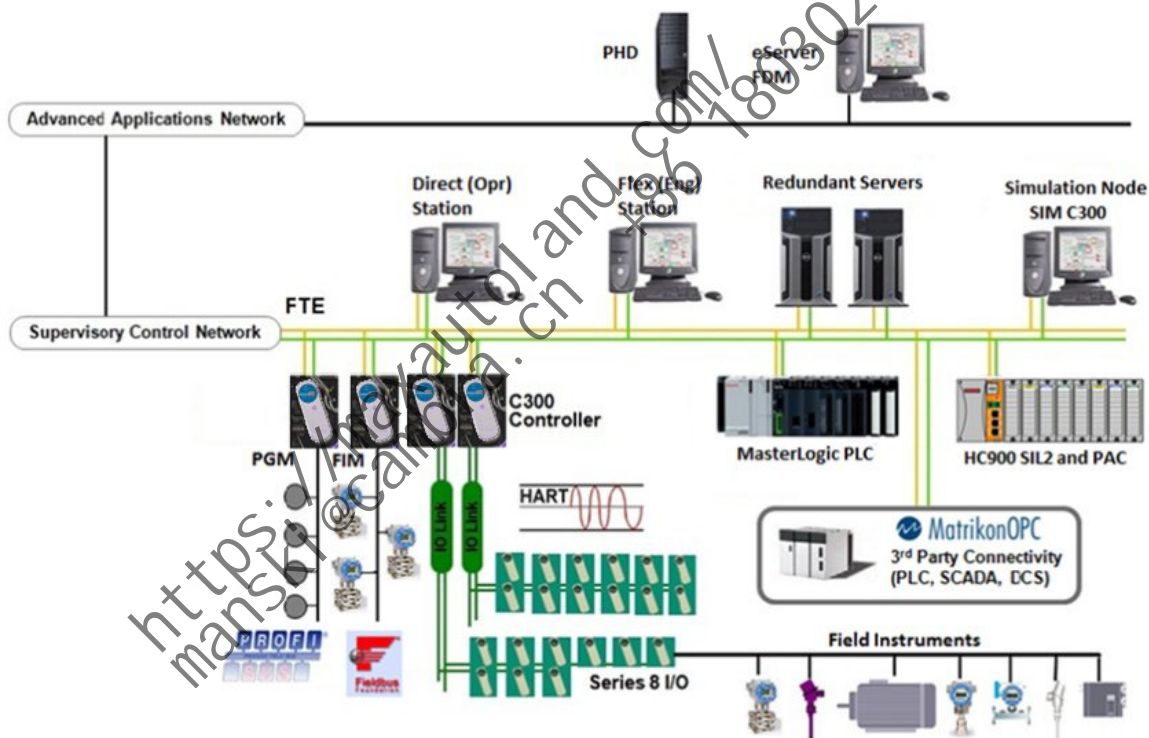

Figure 1 - Sample Experion LX Architecture

1.2. Series 8 Profibus Gateway Module Overview

This document provides technical information for the Series 8 Profibus Gateway Module, released with Experion LX.

The PROFIBUS Gateway Module provides a common module platform to support the interface to the PROFIBUS DP and the C300 Controller. The PGM is developed in the Series 8 form factor for use with the C300 Controller. The Series 8 form factor employs an Input Output Termination Assembly (IOTA) and an electronics module which mounts and connects to the IOTA.

As a PROFIBUS gateway, PGM is always a master and communicates with the PROFIBUS compatible slave devices.

The PGM mounts in the same fashion and shares all characteristics, power and grounding, certifications, and meets all environmental rating as all other Series 8 components.

The PGM is optionally redundant and supports two DP networks per module.

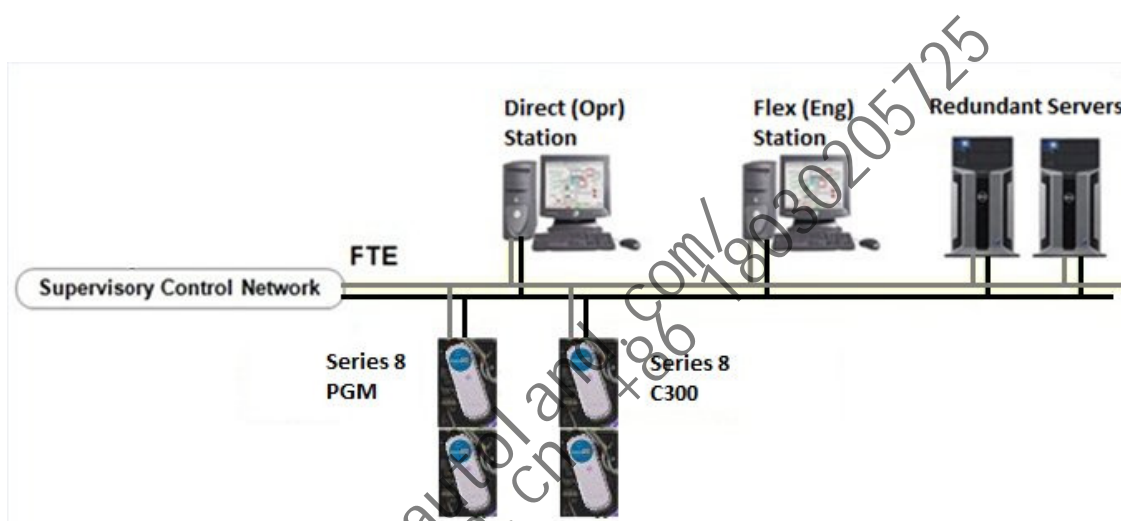

Figure 2 - Experion LX Architecture with PGM

2. Specifications

Specifications for Series-8 I/O modules are shown below.

2.1. Series 8 Profibus Gateway Module Hardware

The PGM supports the following functions.

- Redundancy
- Cold start command
- Experion LX by Experion events and alarms
- Experion LX by Experion Bulk Build utility
- Experion LX by Experion import/export functionality
- Qualification and Version Control
- Peer-to-peer communications

Series 8 IOTA Layout

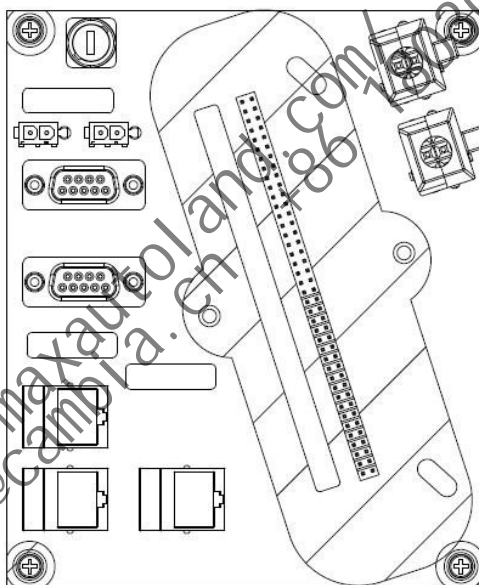

Figure 3 - . Series 8 PGM IOTA Layout

IOTA Characteristics:

- Standard six inch Series 8 IOTA
- Mounts onto a standard Series 8 carrier channel assembly. Power per header board through cables.
- Redundancy is configured with two IOTAs interconnected by a redundancy sync cable (orange CAT5e, uses the same as those used for C300 redundancy).
- Provides two to 9-pin D-subminiature female PROFIBUS network connections.
- Each 9-pin D-sub connector provides 5 VDC +/-5% for terminator bias voltage (power is sourced from the PGM module).
- Provides Cat5e connections for standard FTE cables.
- Provides 3 rotary switches to set FTE device index (address)

Series 8 PGM Connections:

As with all Series 8 modules, the PGM mounts on a Series 8 IOTA (I/O Terminal Assembly). There is only one (6 inch) IOTA for the PGM. Redundancy is accomplished using two IOTAs, two PGMs, and an interconnecting sync cable.

IOTA connectors:

FTE A (yellow) and FTE B (green) CAT5e connectors.

A DB9F connector for DP network 1 (top) and 2 (bottom).

A CAT5e connector for the redundancy sync cable. This is used when the PGM is configured in a redundant configuration. The sync cable interconnects to the primary and backup IOTA and PGM modules.

Three thumb wheel switches to establish the PGM FTE index address. When redundant, primary PGM is assigned an odd address and backup is set to the next even address.

As with all Series 8 modules and IOTAs, power and grounding is accomplished using the I/O Link cables and header board arrangement.

<https://maxautoland.com/>
+86 18030205725
manski@cambid.com.cn

Detailed Specifications, Modules, and Capacities – Profibus Gateway Module

Parameter		Specification
Input / Output Model		8C-IP0102, PROFIBUS Gateway ASSY, Coated 8U- IP0102, PROFIBUS Gateway ASSY, Uncoated
IOTA (64pt) PWA		8C-TPOXA1, Coated 8U-TPOXA1, Uncoated
Supervisory network type		Series 8 PGM is a standard FTE node.
Voltage Rating		24 VDC
Module current rating		430 mA
Temperature	Operating Temperature	0 to 60 °C
	Storage temperature	-40 to 85 °C
Series 8 PGM mounting		Mounts on the standard Series 8 mounting assembly (on an IOTA) and must mount in a standard Series 8 cabinet.
Series 8 PGM power and grounding		Must use the standard Series 8 power system.
PROFIBUS DP (V0) supported?		Yes – including standard and extended status bytes.
PROFIBUS DP (V1) supported?		PGM acts as a DP Master Class-2 device for FDM. FDM uses vendor provided DTMs to enable DPV1 messaging over the DP network. Profidrive DSB has some V1 capabilities (see users manual).
Module Removal and Insertion Under Power		Supported
PROFIBUS DP (V2) supported?		Not supported in release R110.
DP network media redundancy		Supported using 3rd party Redundancy Link Modules (like ABB RLM and Siemens Y Link).
DP Slave device redundancy		DP network can include redundant slaves. PGM has no V1 capability with respect to Slave redundancy. FDM may be able to manage this using vendor supplied DTMs.
PROFIBUS PA and PA devices supported?		Yes, using 3rd party PA to DP converters/couples.
Asset Management?		Yes- Using Honeywell FDM. PGM acts as a Master Class-2 device allowing FDM to access the DP network and DP Slaves. FDM utilizes DTMs to communicate with DP slaves.
Simulation supported?		No simulation capabilities for R110.
HART over PROFIBUS support		Yes – Using FDM and Slaves that support HART devices.
Agency certifications		
		 Class I, Division 2, Group A, B, C, D; T4 Class I, Zone 2 AEx/ Ex nA II C T4
		 Class I, Division 2, Group A, B, C, D; T4 Class I, Zone 2, Ex nA II C T4

PGM Capacities and Limits

Capacity Item	Limit or Constraint
Maximum number of Series 8 PGMs per Server (or redundant server pairs)	80 redundant or non-redundant.
Maximum number of Series 8 PGMs per C300. Note: for R110 a given PGM can be assigned to one and only one C300 (or redundant pair). No other peer connections are allowed.	4 PGMs or redundant pairs (8 DP networks)
Maximum number of DP networks per PGM	2
Address range per DP network.	0-125
Maximum number of Slaves and Masters per DP network (DP Stations). Note: per RS485 standard, maximum number of devices per a given electrical segment is 32. Repeaters are required to achieve the maximum of 125.	Theoretical max is 125 but other factors (like memory/latency time) will govern the actual max implemented on a given project.
Maximum number of DSB blocks per PGM Note: A DSB (Device Support Block) is used to represent one slave on the DP network.	250
Maximum number of different DSB (Slave) types per PGM. Note: A DSB (Device Support Block) is used to represent one slave on the DP network.	20
Maximum number of different PDC types per DSB	16

PGM Configuration Options

PGM2 Configuration Specifications	
PROFIBUS Communication Profiles Supported	DP (only) – PGM2 is DP Master Class-1
PROFIBUS Baud Rates Supported ¹	12 Mbps, 6 Mbps, 3 Mbps, 1.5 Mbps, 500 Kbps, 187.5 Kbps, 93.75 Kbps, 19.2 Kbps, 9.6 Kbps
Support for Multi-Master Configurations	Yes
Support for PROFIBUS Slave Diagnostics	Yes
Valid PROFIBUS Station address range ²	0 - 127
Number of PROFIBUS Networks per PGM2	2
Maximum Input Data Size per PGM2 PROFIBUS Network (all slave stations). For DP V0 input data.	3.5K Bytes per DP network
<p>Note 1 – Each PROFIBUS Network per PGM2 may be configured with a different Baud Rate. Any change to the PGM2 Baud Rate may require restart of all PB slave devices.</p> <p>Note 2 – Some PROFIBUS Station Addresses are reserved for special purposes as follows: Address 0 is Master class 2 default address Address 1 is reserved for master class 1 (PGM2) Address 2 is reserved for slave with changeable address Address 126 is reserved for slave with changeable address Address 127 is reserved for broadcast messages Addresses 3 – 125 are reserved for PROFIBUS slaves</p>	

2.2. Series 8 PGM & Control Processor Integration

C300 Integration

Refer to [Figure 4](#) - Series 8 PGM and C300 Integration (Local Configuration) and [Figure 5](#) - Series 8 PGM and C300 Integration (Remote Configuration) below, which show the PGM is a standard FTE node and interfaces to the C300. The figure shows a redundant configuration, but the PGM can also be implemented in a non-redundant configuration by using only one PGM.

[Figure 4](#) - Series 8 PGM and C300 Integration (Local Configuration) depicts a typical local configuration. Both the C300 and PGMs are in the same cabinet complex and use the same

[Figure 5](#) - Series 8 PGM and C300 Integration (Remote Configuration) depicts a typical remote configuration. The C300 is in one cabinet and PGM is in another cabinet. In this case the PGM is remote from the C300 (or local to the process equipment).

Important Note: Differences for end-to-end response time between local and remote configurations is negligible. Recovery time from FTE fault difference is significant – rough numbers are a few hundred msecs (local) vs. a few seconds (remote).

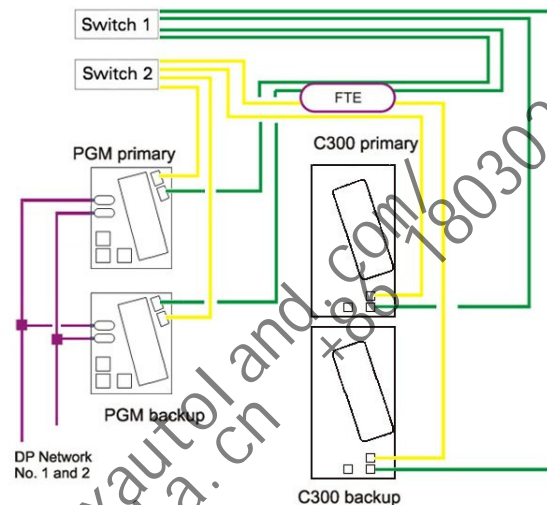

Figure 4 - Series 8 PGM and C300 Integration (Local Configuration)

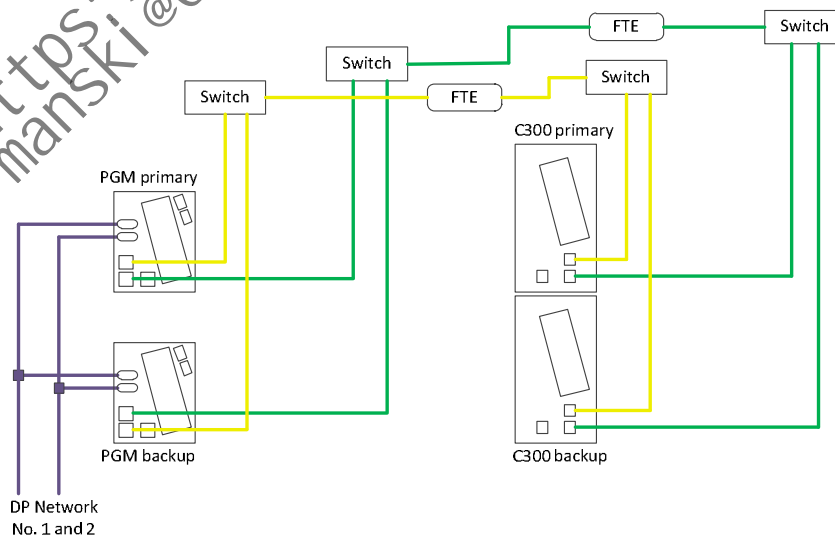

Figure 5 - Series 8 PGM and C300 Integration (Remote Configuration)

Experion™ is trademarks of Honeywell International Inc..

All other products and brand names shown are trademarks of their respective owners.

This document contains Honeywell proprietary information. It is published for the sole usage of Honeywell Process Solutions' customers and prospective customers worldwide. Information contained herein is to be used solely for the purpose submitted, and no part of this document or its contents shall be reproduced, published, or disclosed to a third party without the express permission of Honeywell International Inc..

While this information is presented in good faith and believed to be accurate, Honeywell disclaims the implied warranties of merchantability and fitness for a particular purpose and makes no express warranties except as may be stated in its written agreement with and for its customer.

In no event is Honeywell liable to anyone for any indirect, special or consequential damages. The information and specifications in this document are subject to change without notice.

<https://maxautoland.com/>
manski@cambid.com.cn +86 18030205725

Sales and Service

For application assistance, current specifications, pricing, or name of the nearest Authorized Distributor, contact one of the offices below.

ASIA PACIFIC

Honeywell Process Solutions,
(TAC) hfs-tac-support@honeywell.com

Australia

Honeywell Limited
Phone: +(61) 7-3846 1255
FAX: +(61) 7-3840 6481
Toll Free 1300-36-39-36
Toll Free Fax:
1300-36-04-70

China – PRC - Shanghai

Honeywell China Inc.
Phone: (86-21) 5257-4568
Fax: (86-21) 6237-2826

Singapore

Honeywell Pte Ltd.
Phone: +(65) 6580 3278
Fax: +(65) 6445-3033

South Korea

Honeywell Korea Co Ltd
Phone: +(822) 799 6114
Fax: +(822) 792 9015

EMEA

Honeywell Process Solutions,
Phone: + 80012026455 or
+44 (0)1344 656000

Email: (Sales)

FP-Sales-Apps@Honeywell.com

or

(TAC)

hfs-tac-support@honeywell.com

AMERICA'S

Honeywell Process Solutions,
Phone: (TAC) 1-800-423-9883 or
215/641-3610
(Sales) 1-800-343-0228

Email: (Sales)

FP-Sales-Apps@Honeywell.com

or

(TAC)

hfs-tac-support@honeywell.com

Specifications are subject to change without notice.

For more information

To learn more about SmartLine Transmitters,
visit www.honeywellprocess.com
Or contact your Honeywell Account Manager

Process Solutions

Honeywell
1250 W Sam Houston Pkwy S
Houston, TX 77042

Honeywell Control Systems Ltd
Honeywell House, Skimped Hill Lane
Bracknell, England, RG12 1EB

Shanghai City Centre, 100 Jungi Road
Shanghai, China 20061

www.honeywellprocess.com



S803-160-110, Ver.1

January 2014

©2014 Honeywell International Inc.